

Drama and Context in Real-Time Virtual Environments: Use of Pre-Scripted Events as a Part of an Interactive Spatial Mediation Framework

Michael Nitsche and Stanislav Roudavski with
François Penz and Maureen Thomas¹

Digital Studios for Research in Design, Visualization and Communication,
University of Cambridge, Department of Architecture,
1 Bene't Place, Lensfield Road, Cambridge CB2 1EL, UK
{michael.nitsche, stanislav.roudavski}@cumis.cam.ac.uk
<http://www.arct.cam.ac.uk/cumis/>

Abstract. We suggest that the dramatically engaging mediation of an experience of place should be built in as a fundamental capability of a compelling and meaningful virtual environment (VE). Our main objective is to develop flexible interactive techniques that supply VE's with a coherent context and make the resulting 'virtual place' available to the user in a dramatically engaging way. To support the concept of narrative expressive space, we propose a three-layer multi-purpose spatial mediation framework that utilizes an interactive narrative structure to coordinate stylized dramatic camera work, lighting, effects and sound. We then describe the use of pre-scripted events as a layer in this framework and explain the inherent benefits and problems, using a single-user prototype environment as illustration. The work offers guidelines for the design of VE's to all fields that combine narrativity and spatiality, such as interactive entertainment, education and architecture.

1 Introduction

Current consumer-level technologies (Feb 2003) support visually sophisticated three-dimensional richly interactive VE's. However, the potential of these environments will only be fulfilled if users can be attracted to visit them. We believe that the success of any application in a VE depends to a large extent on how the environment succeeds in engaging its user. We suggest that integrating generators of dynamic dramatic tension between users and environment into the design of VE's is an effective way of engaging participators. The framework and the use of pre-scripted events described below is the result of the practice-based *Haven* research project.

¹ The names are grouped in alphabetical order

In TIDSE '03 *Technologies for Interactive Digital Storytelling and Entertainment*, S.Goebel, N.Braun, U.Spierling, J.Dechau, H.Diener (eds.) Darmstadt, Germany, 24-26 March 2003. Fraunhofer IRB Verlag, Stuttgart, ISBN 3-8167-6276-X. pp 296-310

1.1 Place

Philosophers such as Merleau-Ponty and Heidegger introduced the phenomenon of place into the discourse about space. We cannot live in or experience homogeneous Euclidian space. Our experience of space is conditioned by the presence of our body, our knowledge, purpose, skill and mood. Understood as a system of possible actions, the active body is defined by the space it occupies. The space becomes a system of holistic phenomena accessible through direct experience - it acquires an existential quality. 'Being' becomes synonymous with 'dwelling' or 'being situated'. The multi-disciplinary ecological approach (with proponents in environmental psychology (e.g. [21][7]), environmental aesthetics (e.g. [9]), urban planning and architecture (e.g. [19, 20][13]) among others) claims that subjects cannot be dissociated from their environments. Endowed with meaning, environmental dynamics, cultural and historic content, 'space' evolves into 'place'. We suggest that the phenomenon of place can be used as an effective metaphor for conceptualizing VE's.

1.2 Drama

Drama is captivating to literary, theatrical and cinema audiences alike. Its power transcends media boundaries and is based on the enacted expression of conflict. The enactment of conflict overcomes audiences' indifference to the unfolding events [15]. The origins of this conflict are diverse (Seger distinguishes between inner, relational, social, situational, and cosmic conflict [24]) and support wide scope for content.

We propose that drama offers a powerful way to add meaning to VE's, encourage users to interact with the environment, other users, and relate places to each other. In addition, drama can help structure the distribution of VE spatial content in an accessible, effective and economical way.

1.3 Role of Mediation

VE's lack a 'natural' point of view (POV). A layer of mediation separates the user from a synthetic 3D space [11, 12]. Such mediation can be regarded as a hindrance. Conversely, like the Formalists, we believe that mediation provides a unique opportunity to draw on the rich visual language developed in traditional dynamic media such as cinema [1][16]. The term mediation here is inclusive of all the visual, audio (and, potentially, other, e.g. tactile) means with which a virtual experience is presented to the user. Conventionally arranged around cinematic metaphors in authoring software, these include animated cameras, lights, effects and sounds. In addition, animated elements such as textures or shapes contribute to the rendered result and can also be considered as mediation devices. Without these means, a VE does not emerge from an inaccessible mathematical abstraction.

2 Spatial Mediation Framework

Our framework, which emerges from practice-based research prototyped at our Studios [18], consists of three equally important constellations of mediation devices that each delivers spatial content differently. Every constellation has a distinct balance between freedom of interaction and authorial control. Combining them provides complementary expressive resources. The constellations are: *User Driven*, *Spatially Dependent* and *Author Defined*. Each constellation offers its own specific dramatization techniques but all are interconnected.

2.1 User Driven

The main constituents of this constellation are the (virtual) cameras, fixed or mobile relative to the user avatar, and always under some degree of user control. Avatar movement can also be explicitly controlled by the user, with an input-device such as keyboard or mouse. The approach is typical of the 1st-person or 3rd-person POV cameras used in games and other interactive titles. Transitions from one camera to another, which happen rarely, are also usually initiated by the user. There is little in-built dependency between the camera, the space and the event. User-driven camera strategy results in monotonous design and dramatic expression, since camerawork is predominantly concerned with the description of the avatar and its actions, rather than the expression of dramatic emotion.

Interactivity, immersion and freedom of exploration, acknowledged positive qualities of VE's [e.g. 17], require a high degree of user control, and this restricts the capacity of avatar-centered cameras to depict space or anticipate spatial events.

In our framework, despite their self-referential nature, the cameras of the user driven constellation are linked to the dramatic requirements of the surrounding space and the narrative moment. The system (driven by rule-based or AI logic) determined by the author, can initiate cuts between a set of user-related cameras and control their motion as a function of user input. Shots and POV's can be intelligently selected to maintain the desired style and rhythm (e.g. continuity style conversation depiction in cinema) or direct attention to an event.

2.2 Spatially Dependent

This constellation includes the cameras as well as the other means of mediation triggered, conditioned and driven by user avatar position, orientation and movement in space. Users directly control avatar movement but not the camera. The mediation system is made aware of the spatial topology featuring significantly in the mental image of the user (as described by the Norberg-Schulz/Lynch theory [19, 20][14]) that distinguishes between spatial elements (*node, path, region*) and space defining elements (*edge, landmark*).

VE designers use this theory to interpret the space for mediation and implement their design decisions through manual scripting, partial automation or AI. As the

spatial elements in the arsenal of the designer are akin to those that form the mental image of the user, indirect manipulation of this image for dramatic purposes becomes possible.

The idea that Norberg-Schulz/Lynch theory can be used to aid orientation and navigation in VE's is not new [3][4][25][27]. However, we suggest that the presence, meaning and relationship of these elements in the mental image of a VE user can be manipulated in accordance with dramatic logic to create an engaging experience.

For example, *regions* can be imbued with distinct emotional and dramatic content to reinforce significant changes in spatio-functional patterns and add meaning to underlying spatial topology using distinct cinematic strategies, with characteristic camera-work and stylized lighting and sound.

In our framework, the mediation devices of this constellation give the user freedom to explore and interact with the environment. However, this freedom is selectively limited or conditioned in order to establish spatial relationships with other avatars/objects or the environmental features, to direct attention, or to build up dramatic tension.

2.3 Author Defined

This constellation includes the events triggered by the user with little or no direct user input. Orchestrating the pre-defined actions of the animated cameras, lights, textures, effects, sounds and autonomous characters amounts to a predominantly pre-scripted event. Limited in interactivity, such events can exploit the descriptive power of cinematic language to portray a defined dramatic situation.

Many interactive titles and, in particular, games, use pre-scripted (even pre-rendered) events, such as the reward events in *Quake III* [22], to connect interactive levels, introduce characters (e.g. the main opponents in *Resident Evil* [23]) or advance the story (e.g. the cut-scenes in *Final Fantasy VII* [6]). In our framework, pre-scripted events can support the experience of 'dramatic place'. Activated by spatial, mobile and conditional triggers our events are designed to add cultural and dramatic context to virtual place rather than create a linear storyline. Conceptualized and implemented as an integral part of the exploratory experience, these can interpret and shape the interactive flow. The detailed description of *User Driven* and *Spatially Defined* constellations is outside the scope of this paper. What follows concentrates on the use and effect of *Author Defined* events in VE's.

3 Haven Project

The principal research question of the *Haven* project is: how can the integration of narrativity and architecture expand the potential of real-time (RT) 3D VE for dramatic engagement? We have experimented with a range of 3D engines and authoring environments. The current implementation of *Haven* is a desktop RT VE with a keyboard and mouse as input devices, and a single screen as output device.

The VE is an imaginary Cambridge college called *Cuthbert Hall*, conceptually defined in reference to existing colleges - characterized as places for research, learning, teaching, work collaboration, and shared social life². *Cuthbert Hall* borrows many architectural features from a traditional college layout. Its cultural and functional context is used as a testing ground to develop techniques that improve meaning and coherence in VE's through narrativity and stimulate user-user and user-environment interaction.

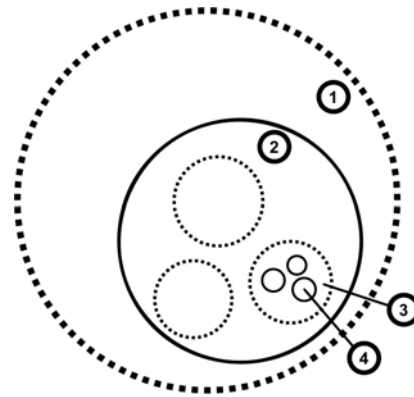

Fig. 1. Socio-cultural context of place: 1) The City of Cambridge (outlines historic and cultural context); 2) *Cuthbert Hall College* (broadly defines the place through its topology, timeframe, functional structure, professional and social routines, symbolism, historical and literary connotations); 3) Spatio-dramatic *region* (places and defines dramatic context); 4) Event (places and defines an exemplary dramatic encounter)

4 Author Defined Constellation: Event Implementation in *Haven*

Specific resident narrative content is delivered as user-triggered events (14 in total) staging emblematic Cambridge college events. Controlled access to staged dramatic events situated in the environment in a meaningful way was the primary goal of the first stage of *Haven*. Here, machine-driven camera control (e.g. [5][8][26]) was not the aim, for the reasons outlined in 2.3 above.

The resident narrative cinematic events are hosted by the different *regions* of the VE. Events consist of pre-scripted, fully or partially controlled sequences mediated through expressive animation, character control, camerawork, sound, and effects.

² *Cuthbert Hall's* fictional history is documented from the foundation of the college in the early 15th century to its disappearance from the cityscape, and the records, during the English Civil War (17th century) owing to ambiguities in political allegiance.

4.1 Themes

The socio-historical context of Cambridge [13] is the primary source of content that supports and is supported by our mediation framework.

The events constituting this content are thematically bundled into the following categories: *Novice*, *Work*, *Death*, *Quarrel* and *Friendship*. Each theme refers to experiences illustrative of Cambridge social and academic life as well as to archetypal emotional situations, which we expect users generally to be able to relate to. In order to tie these staged events to the wider historical context, the events belonging to each category represent a range of historical periods. E.g. The *Quarrel* theme includes not only a stylized academic dispute between 19th-century scholars, but also an example of the vigorous “town vs. gown” encounters of the 18th century. The *Friendship* theme consists of the rich matrix of customary university activities and includes the events set during a Formal Hall dinner, the Lent Bumps rowing races, or the post-exam May Balls. These are important college traditions, which remain alive.

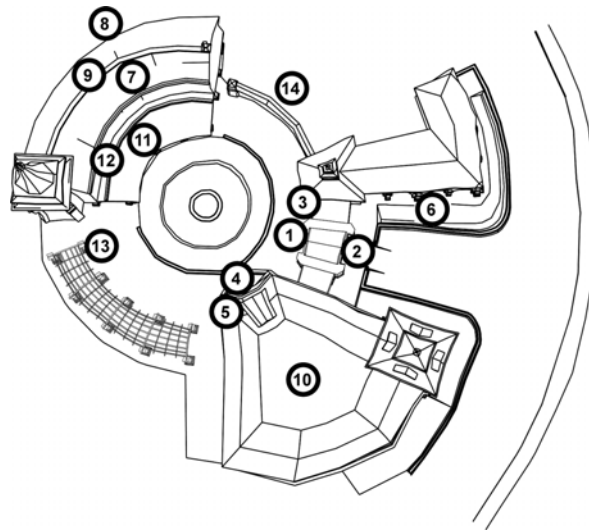

Fig. 2. Cuthbert Hall top view: event locations

Theme	No.	Event	Location	Period
<i>Novice</i>	1	Entry	Porter's Gate	Timeless
	2	Welcome	Porter's Gate	Timeless
	3	Chatting	Porter's Gate Porters	Timeless
<i>Work</i>	4	Lecture	Living Quarters	16 th century
	5	Typewriter	Living Quarters	20 th century
	6	Success	Living Quarters	20 th century

Friendship	7	<i>Dining</i>	<i>Dining Hall</i>	Timeless
	8	<i>Boat race</i>	<i>Dining Hall</i>	Timeless
	9	<i>May ball</i>	<i>Dining Hall</i>	Timeless
	10	<i>Return</i> (phone call)	<i>Living Quarters</i> , trigger at <i>Dining Hall</i>	1945
Quarrel	11	<i>Debate</i>	<i>Dining Hall Colonnade</i>	19 th century
	12	<i>Choir</i> <i>Rehearsal</i>	<i>Dining Hall Colonnade</i>	18 th century
Death	13	<i>Air Raid</i>	<i>Dining Hall</i> , trigger at <i>Backs</i>	1940s
	14	<i>Mourning</i>	<i>Garden</i>	17 th century

4.2 Event Activation

The transition from interactive exploration to a pre-scripted event is triggered when the user avatar enters an invisible, pre-defined, fixed, or mobile spatial zone, so the approximate position of the user at the beginning of the pre-scripted event is known. This engenders spatial continuity between the interactive and pre-scripted sections as the camera anticipates the position of the user avatar.

The trigger-zones have to be of substantial size for the user to set them off when moving through the environment, which means that a minor spatial and visual continuity break might occur on initial triggering, because the user position can be anywhere along the zone boundary. In order to counteract this effect, one approach is to adjust the position of the user avatar to achieve the desired initial framing (c.f. [8]). Our alternative is to systematically adjust the position of the first pre-scripted camera or provide for a transition camera, confining the solution of this problem of mediation to the mediation devices, without involving content.

Another break in cinematic continuity can be caused by the fact that the orientation of the user avatar at the moment of entry into the trigger-zone cannot be precisely predicted. We address this problem in two ways. Firstly, a specific orientation and direction can be encouraged by using drama, with an interactive prequel (e.g. the *Return* event (No. 10) is foreshadowed by a cut-away that encourages the user to approach the trigger-zone). Secondly, the discontinuity can be hidden with cinematic means such as intervening ‘cut-away’ shots with little or no spatial reference. Thirdly, a user avatar animation can disguise the cut. Cinema routinely uses these techniques to motivate and structure narrative editing [10].

4.3 Narrative Space

A conditional network controls activation and de-activation of triggers so even triggers belonging to different events can occupy the same position in space. ‘Positively’ (e.g. *Friendship* theme) or ‘negatively’ (e.g. *Death* theme) charged events can be grouped together as dictated by the dramatic tension in a given location. Varied dramatic rhythm and pace help sustain user interest and encourage further exploration.

The conditional network also manages the rules of content delivery. A loose narrative logic is imposed on the order of event-discovery and activation. Events are made available in author defined (casual, dramatic, temporal) order and activated through user interaction. The majority of the *Cuthbert Hall* events (12 out of 14) can only be triggered once, thus creating an unrepeatable user experience. As users explore the environment and uncover new narrative nuclei, they build their own reading of the interactive context. The character and number of the events discovered color the impact of the environment on the user: the space and content become dramatized.

4.4 Meaning of Place

Dramatic events enhance the experience of a virtual place and contribute to its direct perception as a holistic phenomenon in a number of ways:

Affordances of place. A spatial structure or an object is perceived as a set of affordances [7] whose composition depends on a subject's experience, knowledge, age and cultural background. Using dramatic events, we can alter or rearrange the constituents of the set, assigning new importance or meaning to its members.

So the *Dining Hall* colonnade is not only a sheltering spatial structure with an assortment of associated vistas connecting the *River* and the *Court* – in discovering the related events users gain knowledge of its diverse (e.g. cultural, functional, dramatic) potential. In the *Quarrel* theme (see 4.1 above), the colonnade is a place for scientific debate as well as the location of a street brawl. User expectations and interactive behavior change in reaction to the impact of the situating contexts, and can be directed through the use of spatially located events without intrusive explicit instructions. The VE becomes more effective and engaging as the affordances are made apparent and dramatic tension between them emerges.

In a similar process, the dramatization of space is achieved through purposeful focus on significant spatial/architectural detail. For example, user attention is drawn to the *Dining Hall* window during the *Choir Rehearsal* event but to the colonnade busts during the *Debate*. Made prominent within the events, these architectural features acquire dramatic and spatial significance that remains with them when the fully interactive exploration resumes. Such details, together with the relationships and connotations they generate, enable the developing construction of narrative context.

Relationships in Space. Within our framework, spatial, functional or symbolic relationships between places, spatial components (*path, region, node*) or their defining elements (*landmark, edge*) are also established, made meaningful and memorable through the use of conceptualizing events. The reshaped user-experience results in different perceptions of the environment, an altered mental image of place and, subsequently, altered understanding and behavior. Events such as the *Choir Rehearsal* or the *Welcome* establish the relationship between inside and outside, and delineate routes of action enriching the meaning of the VE in a selective and economical way, dictated by dramatic factors.

Event as a Threshold. The course of user actions is influenced by their encounters with dramatic events, which also bring new interpretations retrospectively to users' interactive experience. Arranged as a link or a threshold, an event introduces a break in the continuum of an interactive user-experience, providing an opportunity to manipulate the balance between the meaning of the pre and post-event interaction. For example, the *Welcome* event is set at a boundary between the city and the college. It emphasizes the moment of entry, and punctuates the symbolic and situational contrast between the user as a part of the noisy 'street' and the user as a novice in the empty college. As an extension of this technique, multiple events can be intercut with interactive navigation to form a sequence.

Temporal Placement. The events are used to suggest the variety of functional dynamics and characters hosted by the college over time. *Cuthbert Hall* features two contrasting time states: early morning and late evening and events relate to these times of day to further reinforce the virtual place by involving the user in a number of significant activities. Scattered along the historic timeline as well as the seasonal cycle, these events appear in the VE as indicative temporal activities.

4.5 Example Event 1: *Debate*

The *Debate* event is situated along the *Dining Hall* colonnade. The establishing shots put the colonnade into a relationship with the surrounding environment, provide views through the arches into the courtyard, and introduce the busts within the colonnade. After the introduction, the event presents close-up shots of the busts that seem to be arguing with each other, each portrayed with a unique shot. This is a dramatic, not purely descriptive, approach, as the event engages the user as an addressee of the debate.

The strong emphasis on the busts themselves diverts attention from courtyard layout - these camera tactics create dramatic rather than merely spatial relationships between the busts and the user.



Fig. 3. An excerpt from the *Debate* event (I); wide establishing shots relate the colonnade and the user avatar to the surroundings before close-ups concentrate on the busts

The event steers the user avatar from one end of the colonnade to its midpoint and then the debate between the busts cuts in. When the user regains control, the avatar is at the other end of the colonnade. In addition to the spatial knowledge acquired during the interactive exploration, the user’s cognitive map of the colonnade is disturbed by the purely cinematic event - one part of the spatial sequence has been omitted.



Fig. 4. An excerpt from the *Debate* event (II); different angles on busts lack the reference to the surroundings; the concluding view reveals the user avatar standing at the opposite end of the colonnade

Presenting the user with such a “gap” stimulates further exploration. Partial omission is a much-used narrative technique to create suspense (in drama and film), which is applied here in a spatial context. The user is motivated to further interact with the space to fill the gap in knowledge. The busts are situated in their cultural and dramatic context and established as landmarks available as reference for future user interactions.

4.6 Example Event 2: *Choir Rehearsal*

The *Choir Rehearsal* event is located around the *Dining Hall* colonnade - its trigger shares the location but not the timeframe with the *Debate* event. The initial shots establish the user avatar as overhearing a choir rehearsal and direct the user’s attention to the window above the colonnade. The avatar’s glance away from the window towards the *Porter’s Gate* area prepares the second line of action: that of the intruder. The camera then presents this action from a first-person POV, starting in the street

outside, and moving close to ground level through the gate into the main courtyard while the sound of the College Choir singing Beethoven grows louder. At this moment, the camera and not the avatar defines the position of the virtual listener, as it does in evocative cinema.

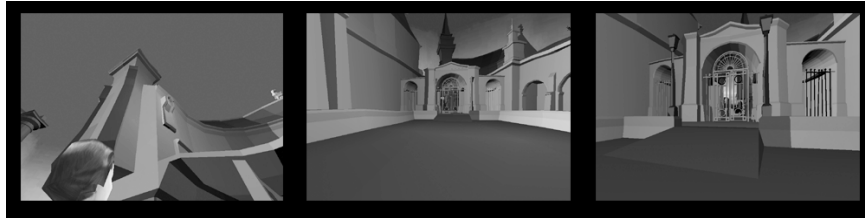

Fig. 5. An excerpt from *Choir Rehearsal* event (I); drawing attention to the window with the gaze of user avatar; the camera moving in from the street and passing through the *Porter's Gate* into the courtyard

At first, the sound of the street is disturbingly mixed with the classical chorale. When the camera passes the gate, the mix changes as the more subtle spatial sounds of the college-interior become audible. The 'outer' space (at the origin of the intruder/camera, which is offered as a first-person POV) and the 'inner' space (the goal of the intruder/camera) are acoustically and visually linked.

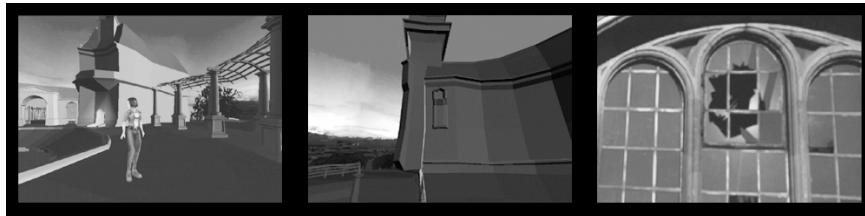

Fig. 6. An excerpt from *Choir Rehearsal* event (II); the avatar's gaze indicates the presence of an intruder; a 'jump-cut' towards the window; the textured view of broken glass

At the peak of the music, the intruder camera 'jump-cuts' towards the window and shows a close-up of broken glass, in sync with the sound of the shattered window-pane interrupting the choir session and followed by the rising shouts of a street squabble until the narrative sequence reaches its dramatic conclusion.

The user avatar inside the court remains a passive onlooker; animation is limited to head movements. However, its gaze draws attention to the window and the rehearsal beyond, turns sidewise - motivating the cut to the outside - and then follows the advancing intruder camera, adding to the feeling of presence of this invisible being. The user-positioning as a witness allows the narrative to unfold, connects the two initial parallel actions, and helps to dramatize the relationship between spaces.

The system allows the user relationship to an unfolding event to be that of

1. A witness (the user observes the choir rehearsal turning into a fight)
2. An active protagonist (the user engages with the *Success* event by triggering paparazzi-like flashes and randomly-generated stills of the user avatar)
3. An addressee (during the *Welcome* event the porter talks to the avatar)

These relationships are established by directing the avatar's gaze to significant elements, positioning the avatar in relation to the environment (e.g. the window or busts), and purposeful framing of the avatar. This approach rejects Laurel's claim [11 and especially 12] for the inevitability of a first-person POV in VE's, borrowing instead from cinematic narrative techniques such as increasing dramatic impact through varying hero/audience positioning [2]. In our framework, the transfer of this approach to RT 3D VE offers new dramatic possibilities not only in staging fiction or games, but also as a means of engagement for any user from directing the attention of a student in an educational application to offering alternative viewpoints on an architectural design.

5 Future Development

Forthcoming practice-based research will concentrate on the task of full implementation of the framework in multi-user environments, to test the creation of dynamic user-environment and user-user relationships through usability studies. *Author Defined* events will add meaning through user-specific dramatic positioning so a particular feature of narrative context can be customized for different users to motivate and structure user-user communication, such as collaboration in a task-based activity, or confrontation in a role-playing situation.

6 Conclusion

The *Cuthbert Hall* VE experiment suggests that dramatic events implemented as a part of a spatial mediation framework, by shaping the user's reading and understanding of virtual space and allowing the incorporation of complex expressive content, substantially increase the capacity of RT 3D VE to engage users.

This paper briefly outlines this three-layer framework, and describes *Author Defined* event-implementation. It discusses architectural approaches to conceptualizing space and relating narrative content to the spatial structure of VE's, and demonstrates how cinematic techniques operate in the interactive setting. We conclude that dramatically mediated space is a valid and desirable condition for a successful VE implementation because it engages users through a direct and evocative experience of place, rather than confronting them with a representation of uncharacterized space.

7 Acknowledgements

Research conducted at the Cambridge University Department of Architecture Digital Studios, supported by Cambridge University Moving Image Studio and Centre for Applied Research in Educational Technologies. Funding from Higher Education Funding Council for England. Software support by Criterion Software, and Funatics Game Development. Technical support by Jonathan Mackenzie, Music/sound by Karina Gretere.

References

1. Bolter, J.D., Grusin, R.: Remediation: Understanding New Media. MIT Press, Cambridge London (1999)
2. Bordwell, D.: Narration in the Fiction Film. University of Wisconsin Press, Madison (1985)
3. Charitos, D.: The Architectural Aspect of Designing Space in Virtual Environments. PhD thesis, University of Strathclyde (1998)
4. Campbell, D.: Design in Virtual Environments Using Architectural Metaphor. MA thesis, University of Washington (1996), <http://www.hitl.washington.edu/people/dace/portfoli/thesis/>
5. Drucker, S.: Intelligent Camera Control for Graphical Environments. PhD thesis, MIT (1994), <http://www.research.microsoft.com/users/sdrucker/papers/thesiswbnakrs.pdf>
6. Final Fantasy VII (computer game) Yoshinori K. (director) JP (1997)
7. Gibson, J.J.: The Ecological Approach to Visual Perception. Erlbaum, Hillsdale London (1986)
8. He, L., Cohen, M., Salesin, D.H.: The Virtual Cinematographer: A Paradigm for Automatic Real-Time Camera Control and Directing. In: Proceedings of SIGGRAPH 96. ACM SIGGRAPH, New Orleans LA (1996) 217-224
9. Kaplan, R.: The Experience of Nature: a Psychological Perspective. Cambridge University Press, Cambridge (1989)
10. Katz, S.D.: Film Directing. Cinematic Motion a Workshop for Staging Scenes. Michael Wiese Publ., Studio City (1992)
11. Laurel, B.: Computers as Theatre. Addison-Wesley Publishing Co., Reading (1991)
12. Laurel, B.: Toward the Design of a Computer-Based Interactive Fantasy System. PhD thesis, Ohio State University (1986)
13. Leedham-Green, E.: A Concise History of the University of Cambridge. Cambridge University Press, Cambridge (1999)
14. Lynch, K.: The Image of the City. MIT Press, Cambridge (1960)
15. Howard D., Mabley, E.: The Tools of Screenwriting: A Writer's Guide to the Craft and Elements of a Screenplay. St. Martin's Press, New York (1993)
16. Manovich, L.: The Language of New Media. MIT Press, Cambridge London (2001)
17. Murray, J.: Hamlet on the Holodeck: The Future of Narrative in Cyberspace. MIT Press, Cambridge (1997)
18. Nitsche, M., Roudavski, S.: Building Cuthbert Hall Virtual College as a Dramatically Engaging Environment. In: Proceedings of the PDC Malmoe 2002, CPSR, Palo Alto CA (2002) 386-390
19. Norberg-Schulz, C.: Genius Loci: Towards a Phenomenology of Architecture. Rizzoli, New York (1980)
20. Norberg-Schulz, C.: Intentions in Architecture. Universitetsforlaget, Oslo (1966)

21. Piaget, J.: *The Child's Conception of the World*. Routledge and Kegan Paul, London (1969)
22. *Quake III: Arena* (computer game) Carmack, J. (designer) USA (1999)
23. *Resident Evil* (computer game) Nakaya, T. (director) JP (1996)
24. Seger, L.: *Making a Good Script Great*. Samuel French, New York London (1994)
25. Strohecker, C., Barros, B., Slaughter, A.: Mapping Psychological and Virtual Spaces. In: *Design Computing on the Net*, International Journal of Design Computing (1998)
<http://www.merl.com/papers/docs/TR98-12.pdf>
26. Tomlinson, W.M.: *Interactivity and Emotion through Cinematography*. MA thesis, MIT (1999)
27. Vinson, N.G.: Design Guidelines for Landmarks to Support Navigation in Virtual Environments. In: *Proceedings of CHI '99*, ACM, Pittsburgh (1999) 278-285
<ftp://ai.iit.nrc.ca/pub/iit-papers/NRC-43578.pdf>